

dLIVE S5000 - without box

Width - 1115.4mm/43.9"
 Depth - 728.5mm/28.7"
 Height - 413mm/16.3"
 Weight - 35kg/77lbs

dLIVE S5000 - with box

Width - 1290mm/50.8"
 Depth - 920mm/36.2"
 Height - 560mm/22"
 Weight - 50kg/110.2lbs

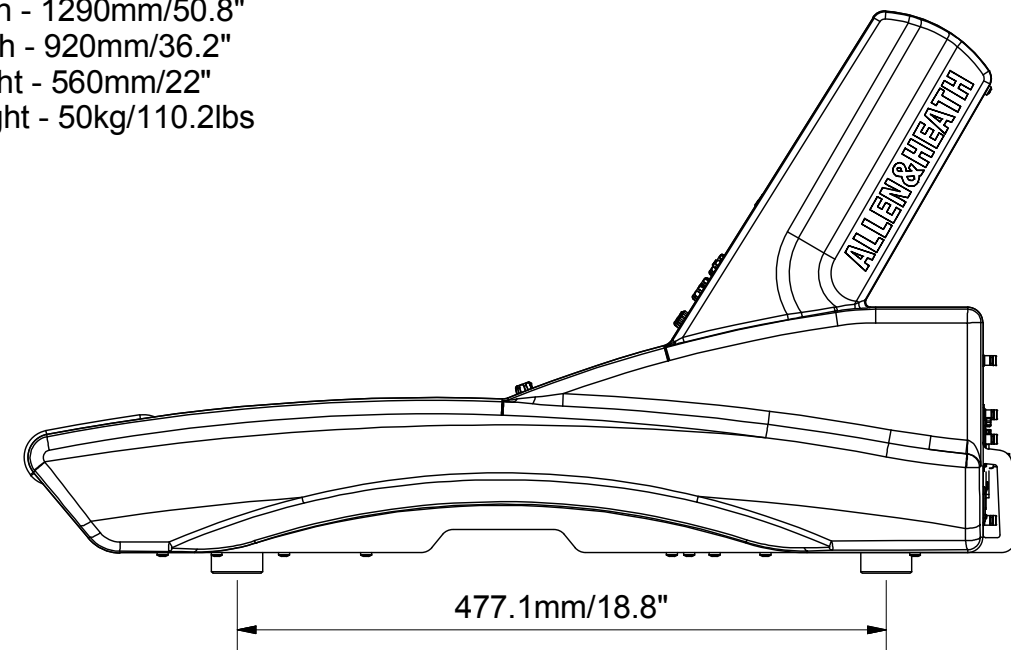
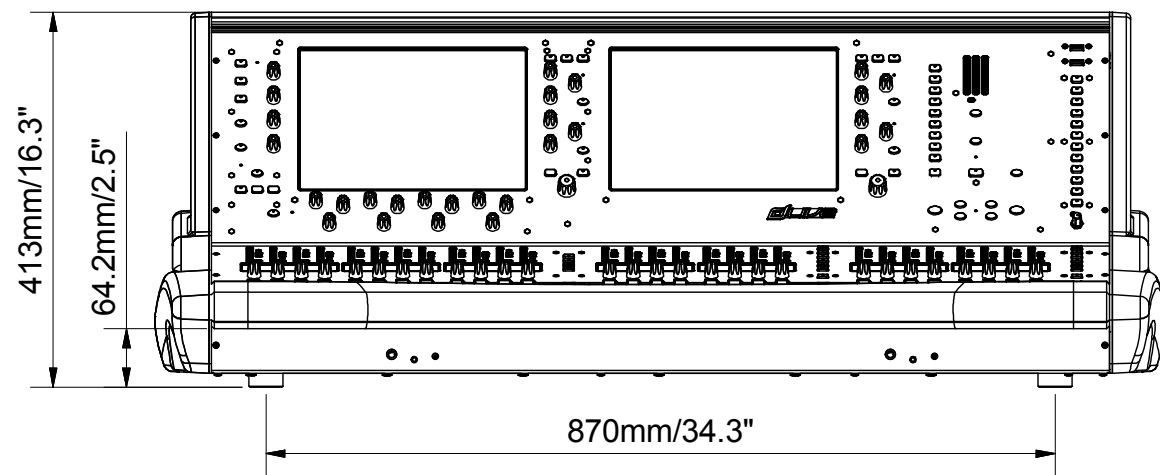

REVISION HISTORY				
REV	DESCRIPTION	ECN	DATE	APPROVED
A	ORIGIN		28/01/2015	Alexmo
B	MECH MOD		23/04/2015	ALEXMO
1	MODS		27/04/2015	ALEXMO
2	TYPO CORRECTION		18/06/2015	ALEXMO

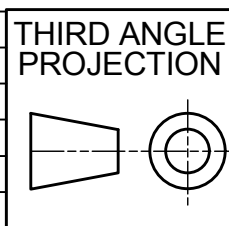

MATERIAL:
 All materials to be compliant with The Restriction of Hazardous Substances (ROHS2) Directive 2011/65/EU

TOLERANCES U O S:
 GENERAL ± 0.25 HOLE CENTRES ± 0.10
 HOLE SIZES ± 0.05 ANGULAR DIMS ± 0.50'

FINISH:

DRAWING DLIVE S5000	
UNIT DLIVE	
PART No 007-158	DRAWING No Weights & Measures DLIVE-S5000

ALLEN & HEATH Ltd. KERNICK INDUSTRIAL ESTATE PENRYN CORNWALL TR10 9LU TELEPHONE 01326 372070 FACSIMILE 01326 370153	
SHEET 1 of 1	ISSUE 2